

Swing Gate Opener User's Manual

For Models: GTR058, GTR100



- Please read and follow all warnings, precautions and instructions before installation and use
- Periodic checks of the operator are required to ensure safe operation
- For residential use only
- Save this manual

R RICHMOND
ENGINEERING

1300 474 246
www.richmondau.com

Rev 18a

| | |
|---------------------------------------|-----------|
| GENERAL SAFETY | 3 |
| PARTS LIST | 4 |
| GTR100 | 4 |
| GTR058 | 5 |
| TECHNICAL SPECIFICATIONS | 6 |
| FEATURES: | 6 |
| QUICK INSTALLATION GUIDE | 7 |
| GATE ARM INSTALLATION | 9 |
| BEFORE YOU START | 9 |
| INSTALLATION DRAWING..... | 10 |
| PREPARATION | 11 |
| GATE ARM MOUNTING | 12 |
| PROGRAMMING AND WIRING | 18 |
| CONTROL BOARD WIRING DIAGRAM..... | 18 |
| MOUNTING THE CONTROL BOX..... | 20 |
| CONNECTING THE GATE ARM..... | 20 |
| PROGRAMMING | 22 |
| PAIRING REMOTE CONTROLS | 24 |
| CLEARING REMOTE CONTROLS | 24 |
| ADJUSTING THE LIMIT SWITCH | 24 |
| INFRARED PHOTOCCELL (GTR051) | 25 |
| BATTERY BACKUP (OPTIONAL EXTRA)..... | 25 |
| SOLAR PANEL KIT (GTR097) | 25 |
| PUSH TO OPEN | 26 |
| OTHER..... | 27 |
| MAINTENANCE | 27 |
| TROUBLESHOOTING | 28 |
| TECHNICAL SUPPORT..... | 28 |

Thank you for choosing this swing gate opener. Please read the manual carefully before assembling and using it. Do not leave out the manual if you send this product to a third party. This product complies with the recognised technical standards and safety regulations. Our company has the right to change the instruction without prior notice.



















General Safety

Warning: Incorrect or improper use of this product can cause damage to persons, animals or properties.



















- Please ensure that the input voltage used matches with the supply voltage of gate opener (AC240V 50Hz).
- All installation and wiring involving 240VAC mains power **MUST** be done by a qualified electrician.
- To avoid damaging gas, power or other underground utility lines, contact the relevant authority BEFORE digging.
- All potential hazards and exposed pinch points of the gate must be eliminated or guarded prior to installation of this gate motor.
- Never mount any device that operates the gate motor where the user can reach over, under, around or through the gate to operate the controls. These must be placed at least 1.8m from any moving part of the moving gate.
- Dispose of all packing materials (plastic, cardboard, polystyrene etc.) according to current guidelines. Keep plastic bags and polystyrene out of children's reach.
- Disconnect the electrical power supply and all batteries before installation or maintenance.
- Keep remote control and other control devices out of children's reach, in order to avoid unintentional activation.
- We recommend fixing a warning sign to the structure.
- If required, install infrared photocells (GTR051) to detect obstructions and prevent injury or damage.
- Warning signs are provided, and should be fixed to the gate on both sides.
- Instruct all users about the control systems provided and the manual opening operation in case of emergency.
- Ensure that the power cable is connected to a properly earthed weatherproof outlet installed by a qualified electrician.
- Do not install the product in an explosive atmosphere.
- This product was exclusively designed and manufactured for the use specified in the present documentation. Any other use not specified in this documentation could damage the product and be dangerous.
- Richmond Wheel & Castor Co declines all responsibility for any consequences resulting from improper use of the product, or use which is different from that expected and specified in the present documentation.
- Richmond Wheel & Castor Co declines all responsibility for any consequences resulting from failure to observe Good Technical Practice when constructing closing structures (door, gates etc.), as well as from any deformation which might occur during use.
- Only use original parts for any maintenance or repair operation. Richmond Wheel & Castor Co declines all responsibility with respect to the automation safety and correct operation when other supplier's components are used.
- Do not modify the automation components, unless explicitly authorised by Richmond Wheel & Castor Co.
- The user must avoid any attempt to carry out work or repair on the automation system, and always request the assistance of qualified personnel.
- This motor is suitable for use on one gate only.
- Anything which is not expressly provided for in these instructions is not allowed and will void warranty.
- Save these instructions for future use.

Parts List

GTR100

| | | |
|---|---|--|
| |  | |
| | Gate Opener (1 pc) w/3m cable | |
|  | Control Box (1 pc) |  CE Remote Control (2 pcs) |
| | Release Key (1 pcs) | |
| | |  Warning Signs (2 pcs) |
|  | Post Bracket (2 pcs) | |
| |  | Post Pivot Bracket (1 pc) |
| | |  Gate Bracket (1 pc) |
| Hardware | | |
|  | Phi 10 Washer (7 pcs) |  M10 x 200 Bolt (4 pcs) |
|  | Phi 10 Lock Washer (7 pcs) |  M10 x 75 Bolt (2 pcs) |
|  | Phi 8 Washer (1 pc) |  M10 x 30 Bolt (1 pc) |
|  | M10 Nut (7 pcs) |  M8 x 30 Bolt (1 pc) |
|  | M8 Nut (1 pc) |  12 x 40 Clevis Pin (1 pc) |
|  | Hairpin Clip (2 pcs) |  12 x 30 Clevis Pin (1 pc) |

GTR058

| | | |
|---|---|--|
| |  <p>Gate Opener (2 pcs) w/1 x 3m cable, 1 x 6m cable</p> | |
|  <p>Control Box (1 pc)</p> |  <p>CE Remote Control (2 pcs)</p> |  <p>Warning Signs (4 pcs)</p> |
|  <p>Post Bracket (4 pcs)</p> |  <p>Post Pivot Bracket (2 pcs)</p> |  <p>Gate Bracket (2 pcs)</p> |
| <p>Hardware</p> | | |
|  <p>Φ10 Washer (14 pcs)</p> |  <p>M10×200 Bolt (8 pcs)</p> | |
|  <p>Φ10 Lock Washer (14 pcs)</p> |  <p>M10×75 Bolt (4 pcs)</p> | |
|  <p>Φ8 Washer (2 pcs)</p> |  <p>M10×30 Bolt (2 pcs)</p> | |
|  <p>M10 Nut (14 pcs)</p> |  <p>M8×30 Bolt (2 pcs)</p> | |
|  <p>M8 Nut (2 pcs)</p> |  <p>12×40 Clevis Pin (2 pcs)</p> | |
|  <p>Hairpin Clip (4 pcs)</p> |  <p>12×30 Clevis Pin (2 pcs)</p> | |

Technical Specifications

| | GTR058 | GT100 |
|---------------------------|------------------------------|------------------------------|
| Input: | 240V/50Hz | 240V/50Hz |
| Motor voltage: | 24VDC | 24VDC |
| Power: | 80W each actuator | 80W |
| Current: | 3A | 3A |
| Actuator speed: | 16mm/s | 16mm/s |
| Max. actuator travel: | 385mm | 385mm |
| Max. Weight of the gate: | 400kgs per gate* | 400kgs* |
| Max. Width of the gate: | 5mtrs per gate* | 5mtrs* |
| Ambient Temperature: | -20°C~ +50°C (-4°F to 122°F) | -20°C~ +50°C (-4°F to 122°F) |
| Noise: | ≤60dB | ≤60dB |
| Protection class: | IP44 | IP44 |
| Remote Control Frequency: | 433.92MHz | 433.92MHz |
| Package Weight: | 18kg | 12kg |

*Refer Tables 1 and 2 to confirm suitability.

Features:

- Soft start and soft stop
- Emergency release key in case of power failure
- Dual/Single gate running mode
- Adjustable opening/closing interval between master and slave gate
- Stop/Reverse in case of obstruction during gate opening/closing.
- Built in adjustable auto-close (0-99 seconds)
- Built in max. Motor running time (MRT) adjustable for multiple safety protection (1-50 seconds)
- Digital display indicates the running situation and setting menu
- Reliable electromagnetism limit for easy adjustment
- Can be equipped with a wide range of accessories

Quick Installation Guide

This section contains an overview of the installation process. For more detailed instructions and diagrams, please refer to the relevant section.

1. Check that swing gate is level and swings smoothly; all bearings should be greased and in good condition. Check that the posts are set into the ground securely.
2. For Gate Arm 1, assemble the Post Bracket Assembly and Gate Bracket Assembly, and temporarily connect them to the gate actuator with the clevis pins. Note: Leave the Post Pivot Bracket to rotate freely for the moment.
3. Put the gate arm into manual mode by removing the release plug inserting the key and turning 90°.
4. Move the gate to the fully open position, retract the gate arm fully, then temporarily secure the brackets to the gate and the post with two C clamps. Note that the mounting position should be as per Figure 5. Verify that the gate arm is level.
5. Check that there is at least 2.5cm between the gate and the gate arm as per Figure 10. If clearance is too low, rotate the Post Pivot Bracket and/or move the Post Bracket Assembly.
6. Manually close the gate and verify that it can get to the closed position without reaching the end of the actuator stroke. If the gate can close past the closed position this is okay, it can be adjusted back with the limit switches.
7. While the clamps are still securely in place, carefully close and reopen the gate to check that the gate arm will not bind.
8. Once the position is correct, lock the Post Pivot Bracket with the M8x30mm bolt and nut.
9. Mark the bolt-hole positions on the gate post and the gate itself. Note: Mark the hole in the centre of each slot, this will allow some slight adjustments.
10. Remove the C clamps, then drill 10.5mm diameter holes in the marked locations.
11. Bolt the Post Bracket Assembly and the Gate Bracket Assembly in place using the bolts, washers and nuts provided.
12. Reattach the gate arm with the clevis pins, and check that the gate can open and close smoothly by hand.
13. Once the gate is operating correctly, put the gate arm back into automatic mode by turning the key and replacing the release plug.
14. For GTR058 Dual Gate Opener, repeat steps 2-12 for Gate Arm 2.
15. Disconnect the power cord for the next section to protect the circuit during installation.
16. Mount the control box to a secure surface at least 100cm above the ground. The gate arm lead is 3m long, so ensure that it can reach the control box. (Note: For GTR058 the second gate arm lead is 6m long.)
17. Connect the Gate Arm connector(s) to the outside of the control box.
18. Plug in the power cord to an appropriate weatherproof outlet.
19. Program the Gate Opener using the digital display (refer to page 17 for details).
20. Pair the remote control by pressing the 'LEARN' button until the LED turns on, then press the first button on the remote control twice within 4 seconds. The LED will flash 3 times when pairing is successful.
21. Operate the gate arm to verify that the motor is correctly installed and stops at the right place.
22. Close the control box, ensuring that all wires are in place.

23. Check operation regularly and ensure maintenance is done as required.

Gate Arm Installation

Before you start

The GTR058/GTR100 Swing Gate Automation Kits are suitable for gates up to 400kg per leaf or 5m long. Refer to Tables 1 and 2 to verify that your gate will be suitable. The motor arm uses a worm gear actuator. This kit must be installed on the inside of the property.

The control box comes with a 1.5m long high voltage power cord already wired into the PCB. This should be plugged into an appropriate weatherproof outlet, which must be installed by a qualified electrician. Do not extend the power cable. Make sure the power cord is protected from flooding, tripping and any other damage. If in any doubt, we recommend shielding with a flexible conduit.

Tools Needed:

- Power Drill
- Tape Measure
- Open End Wrenches – 14# & 17# or Adjustable Wrenches
- C-Clamps – small, medium, and large
- Level
- Hacksaw or Heavy Duty Bolt Cutters
- Phillips Screwdriver
- An extra person will be helpful

Single arm

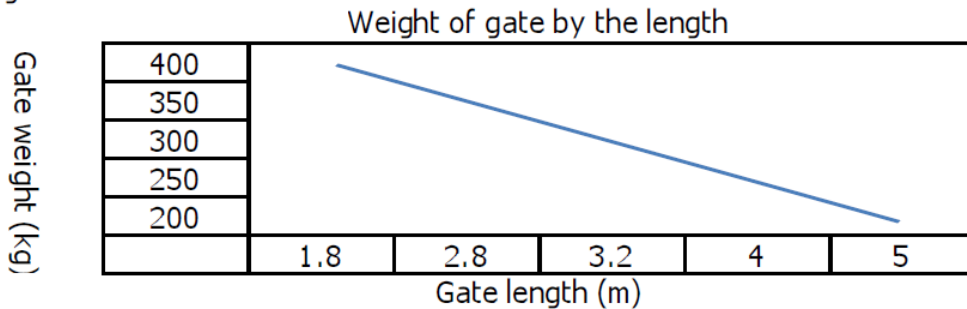

Table 1

Dual arm

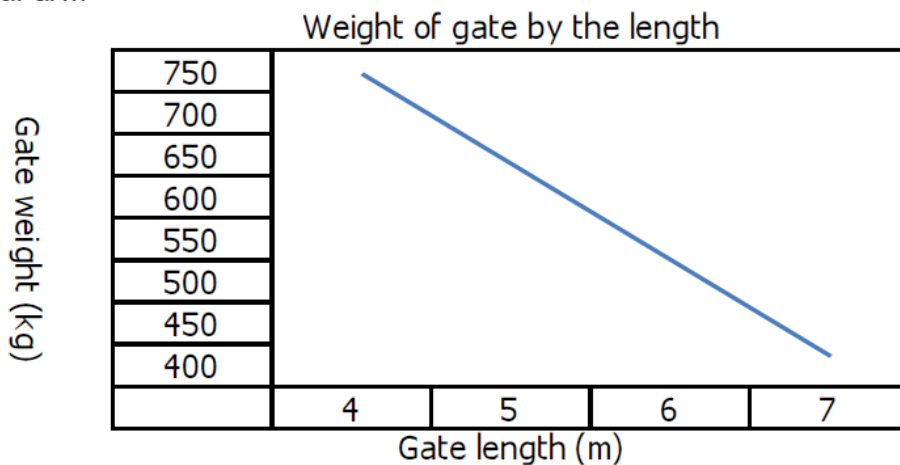
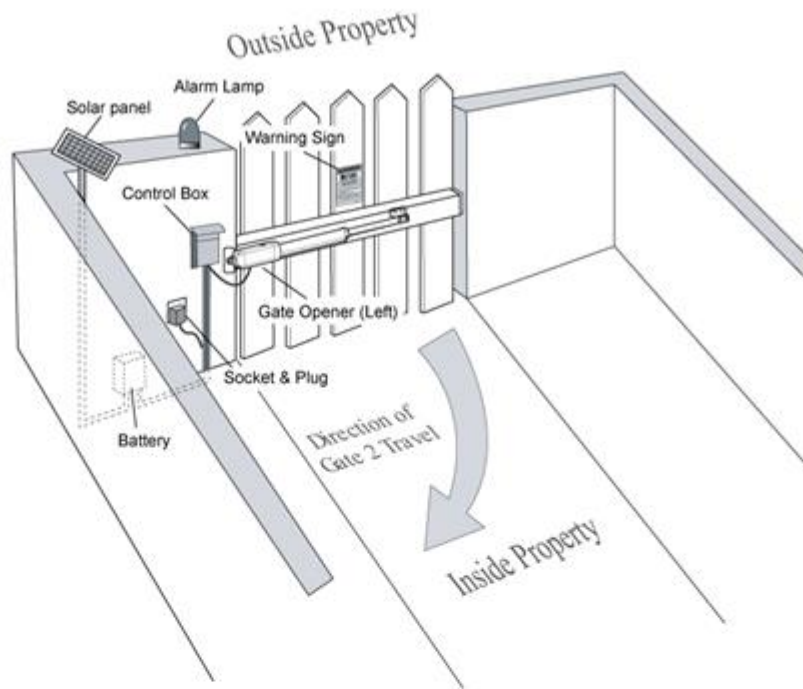

Table 2

GTR100 Installation Drawing

Left-Hand Gate



Right-Hand Gate

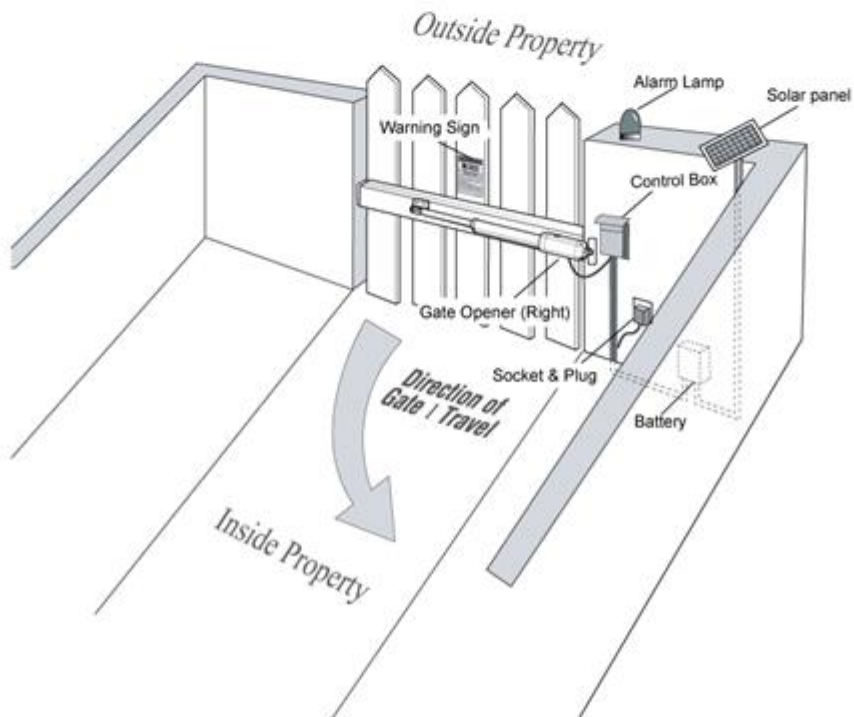

Figure 1

GTR058 Installation Drawing

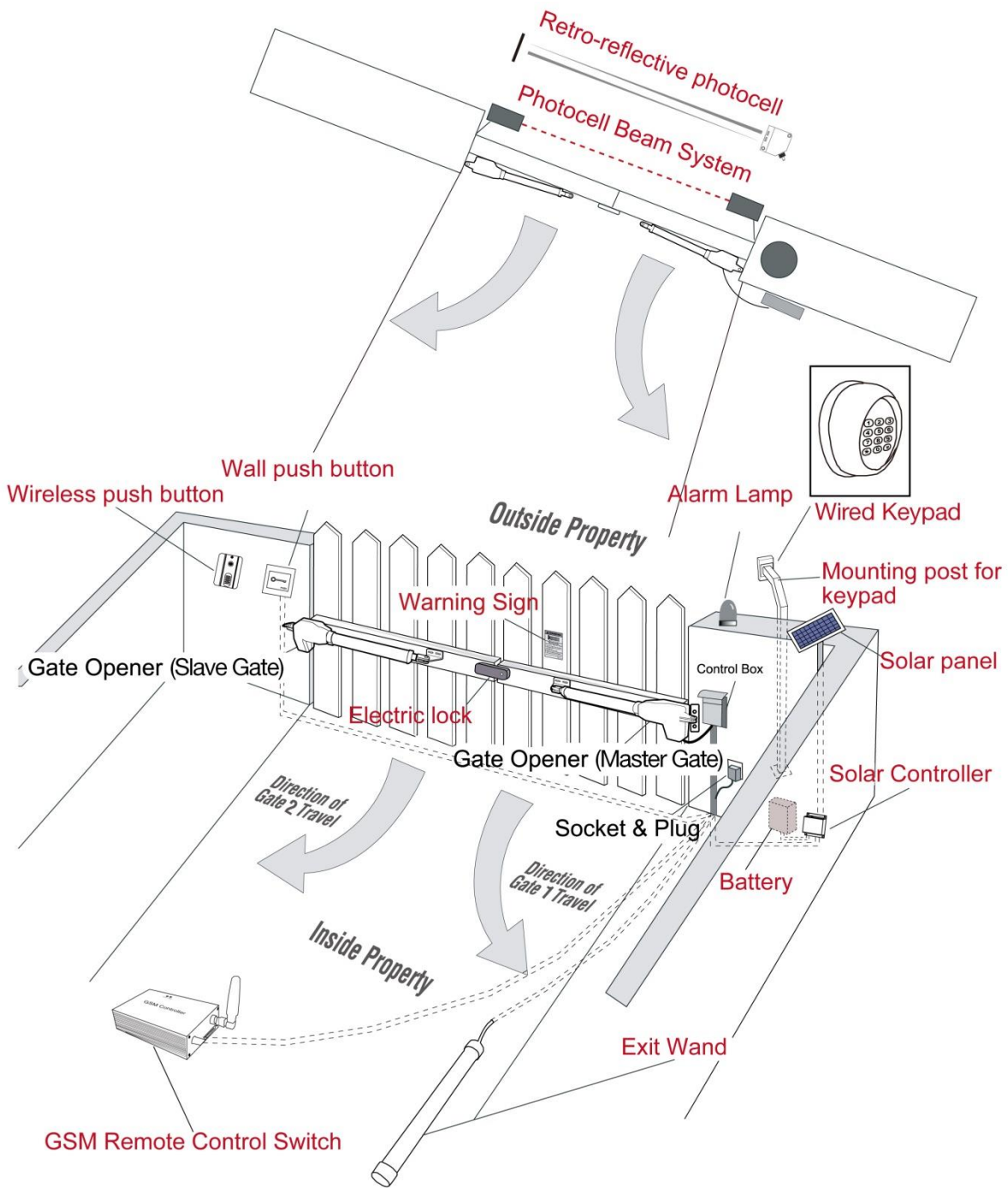

Figure 2

Preparation

Check that the swing gate is correctly installed and level, and that the bearings are greased and in good condition. Any misalignment in the setup of the gate may cause problems with the motor or difficulties opening the gate.

This gate arm is to suit **Pull-to-Open** installation, in which gate opens out from the property. The gate arm can also be used for Push-to-Open installation, see Page 21 of this manual for more details.

Ensure that the gate does not open into public areas.

The gate opener connects to the gate and to the gate post. The Post Brackets provided are curved, so both round and square posts can be used. When mounting the Post Brackets, use bolts long enough to pass through the entire post. M10 x 200mm bolts are included. Concrete anchors are not provided.

When mounting the Post Brackets to wooden posts, a larger-size washer or metal plate should be used between the bolts and the wooden post to ensure the stability of the fastening hardware. If the post is smaller than 6" diameter or square, it should be made of metal and set in cement.

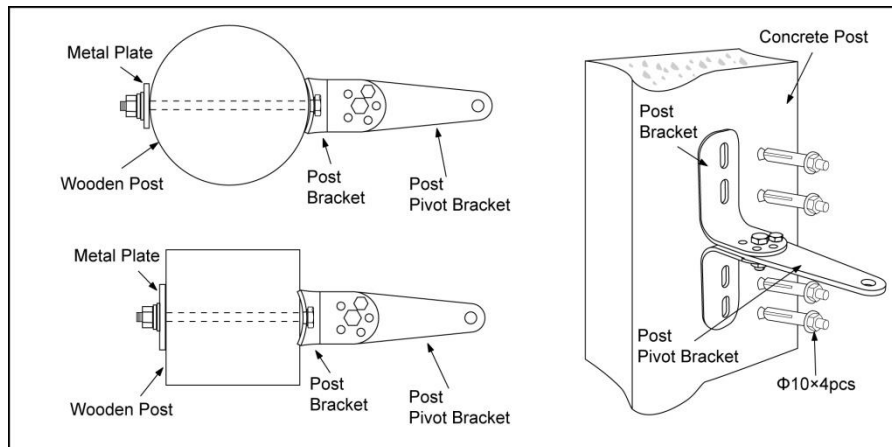

Figure 3

For Dual gates using GTR058, you may need to use conduit or other methods to run the 6m long motor cable underneath the driveway. Ensure that the conduit is big enough that the connector can fit through. For longer gates, extension cables are available from Richmond Wheel & Castor Co, part codes GTR158 and GTR159 refer to 3m and 6m cables respectively.

Gate Arm Mounting

The position of Post Bracket is very important. The following illustrations and tables are required to determine the proper mounting position for the Post Bracket, with the gate in the closed position.

The table in Figure 5 shows the maximum opening angle of the gate for a given A and B. For example, if A is 15cm and B is 20cm, the maximum opening angle of the gate is 110°.

NOTE: Pay attention to distance A when installing the opener. It **MUST** be longer than or at least equal to 8cm (3-1/4"), otherwise, the actuator may not be able to open the gate.

Note: If you are installing GTR058 on a Dual gate, steps 1-13 will apply to Motor Arm 1 (with 3m cable), which should be mounted on the control box side of the property. You will need to repeat these steps for Motor Arm 2 (with 6m cable).

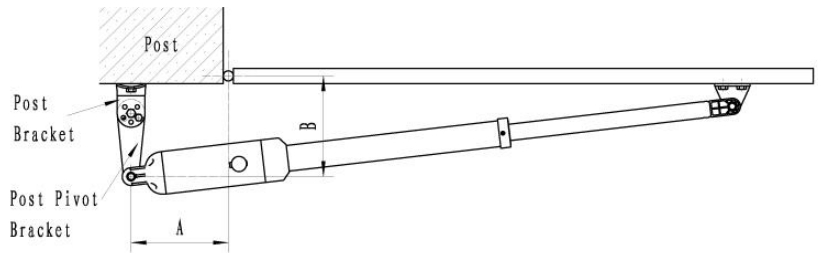

| | A=8cm | A=9cm | A=10cm | A=11cm | A=12cm | A=13cm | A=14cm | A=15cm | A=16cm | A=17cm | A=18cm | A=19cm | A=20cm | A=21cm | A=22cm |
|--------|-------|-------|--------|--------|--------|--------|--------|--------|--------|--------|--------|--------|--------|--------|--------|
| B=19cm | 90° | 93° | 96° | 98° | 101° | 104° | 106° | 108° | 110° | 105° | 102° | 98° | 95° | 93° | 91° |
| B=20cm | 91° | 93° | 95° | 98° | 100° | 103° | 107° | 110° | 104° | 99° | 96° | 94° | 92° | 90° | 89° |
| B=21cm | 91° | 93° | 95° | 97° | 100° | 103° | 106° | 103° | 99° | 96° | 93° | 91° | 89° | 88° | |
| B=22cm | 91° | 94° | 95° | 97° | 99° | 101° | 103° | 98° | 95° | 92° | 90° | 89° | 87° | | |
| B=23cm | 92° | 94° | 96° | 98° | 100° | 103° | 98° | 94° | 92° | 90° | 88° | 86° | | | |
| B=24cm | 90° | 92° | 95° | 97° | 99° | 97° | 93° | 91° | 88° | 87° | 85° | | | | |
| B=25cm | 90° | 92° | 94° | 97° | 96° | 92° | 90° | 87° | 85° | 84° | | | | | |
| B=26cm | 90° | 92° | 94° | 95° | 91° | 88° | 86° | 84° | | | | | | | |
| B=27cm | 90° | 92° | 95° | 90° | 87° | 85° | | | | | | | | | |
| B=28cm | 90° | 93° | 89° | 86° | 84° | | | | | | | | | | |

Figure 4

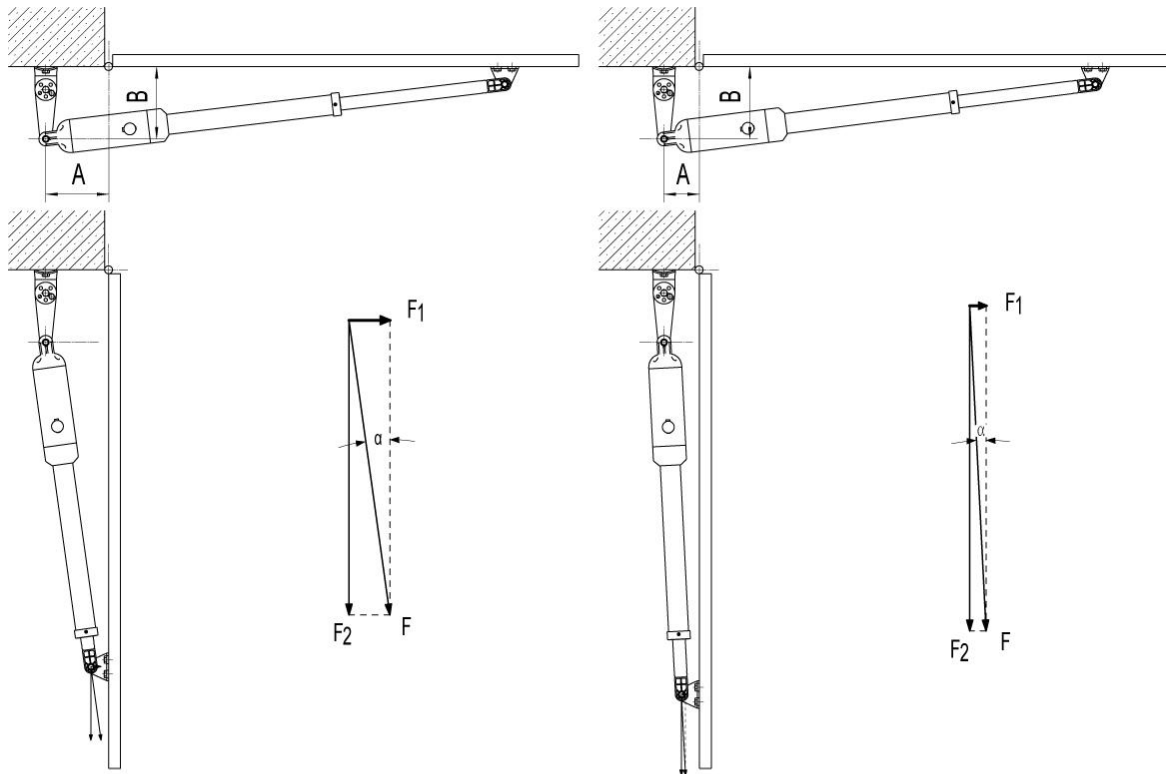

TIPS

- The opener force is composed of effective force F_1 and idle force F_2 . The values of force F_1 and F_2 vary with α - the angle between the gate and axle of opener actuator.
- By the diagram in the right of the force F_1 and α , if the distance A is too short which leads to smaller α , the F_1 will not be big enough to overcome the stall force setting to push or pull the gate ideally.

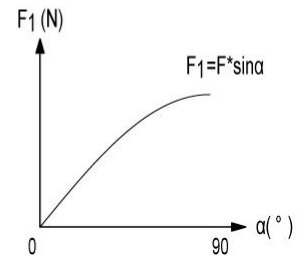

Figure 5

1. Insert the M10 x 30 bolt through the center hole of the post bracket and post pivot bracket as shown in Figure 6. Place a Φ 10 washer, Φ 10 spring washer and M10 nut on the bottom of the bolt and hand tighten so that the pivot plate can swivel.

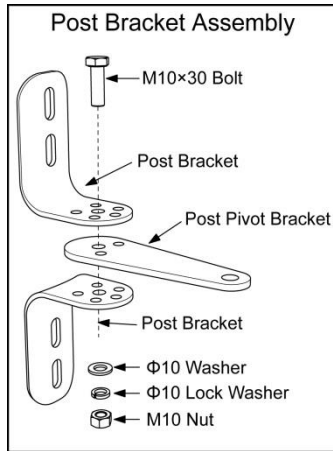

Figure 6

2. Attach the Gate Bracket Assembly and Post Bracket Assembly to the opener by inserting a clevis pin. Temporarily secure the clevis pins using the hairpin clips as shown in Figure 7.

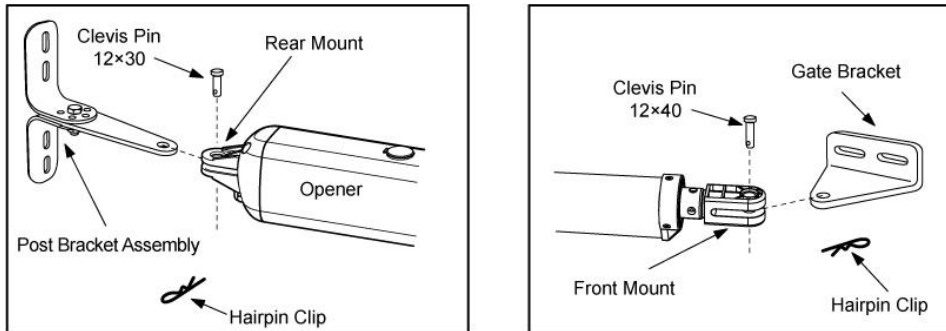

Figure 7

3. Remove the release plug on the top of the gate arm, insert the release key, and turn the key 90° clockwise. This puts the gate arm into manual mode, allowing the gate arm to be manually extended and retracted. To restore normal operation, turn the key 90° anti-clockwise.

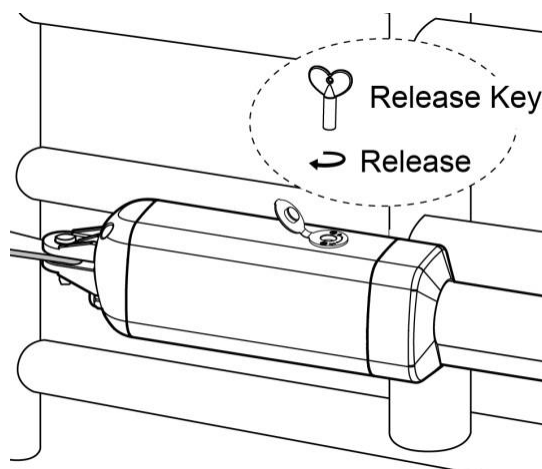

Figure 8

4. With the gate arm fully retracted and the gate in the fully open position, place the gate arm with the Post Bracket Assembly on the gate post and Gate Bracket on the gate. Position the Post Bracket Assembly and Gate Bracket so that the gate arm is level. While holding the gate arm level, temporarily secure it with two C-clamps.

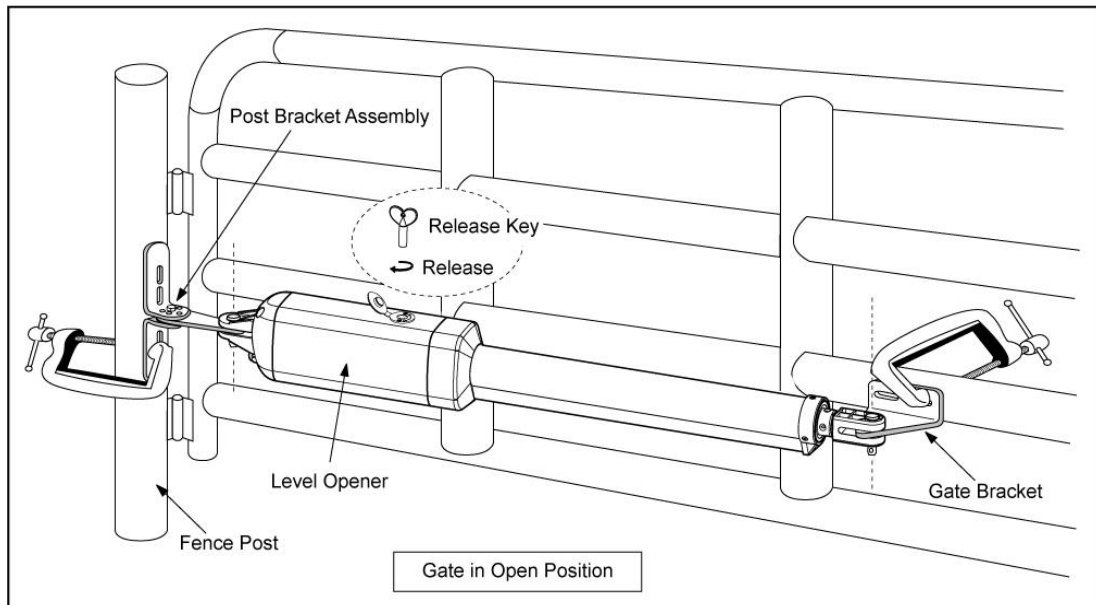

Figure 9

5. Make sure that there is a minimum clearance of 2.5cm between the gate and the opener and that the opener and the Post Pivot Bracket are not binding in both the gate-open and gate-closed positions. If there is not at least 2.5cm of clearance or if the opener and the Post Pivot Bracket are binding, rotate the Post Pivot Bracket and/or move the Post Bracket Assembly to obtain the minimum clearance and eliminate the binding. When the minimum clearance has been obtained and any binding has been eliminated, place the M8 x 30 bolt through the aligned holes in the Post Bracket and the Post Pivot Bracket and hand tighten.

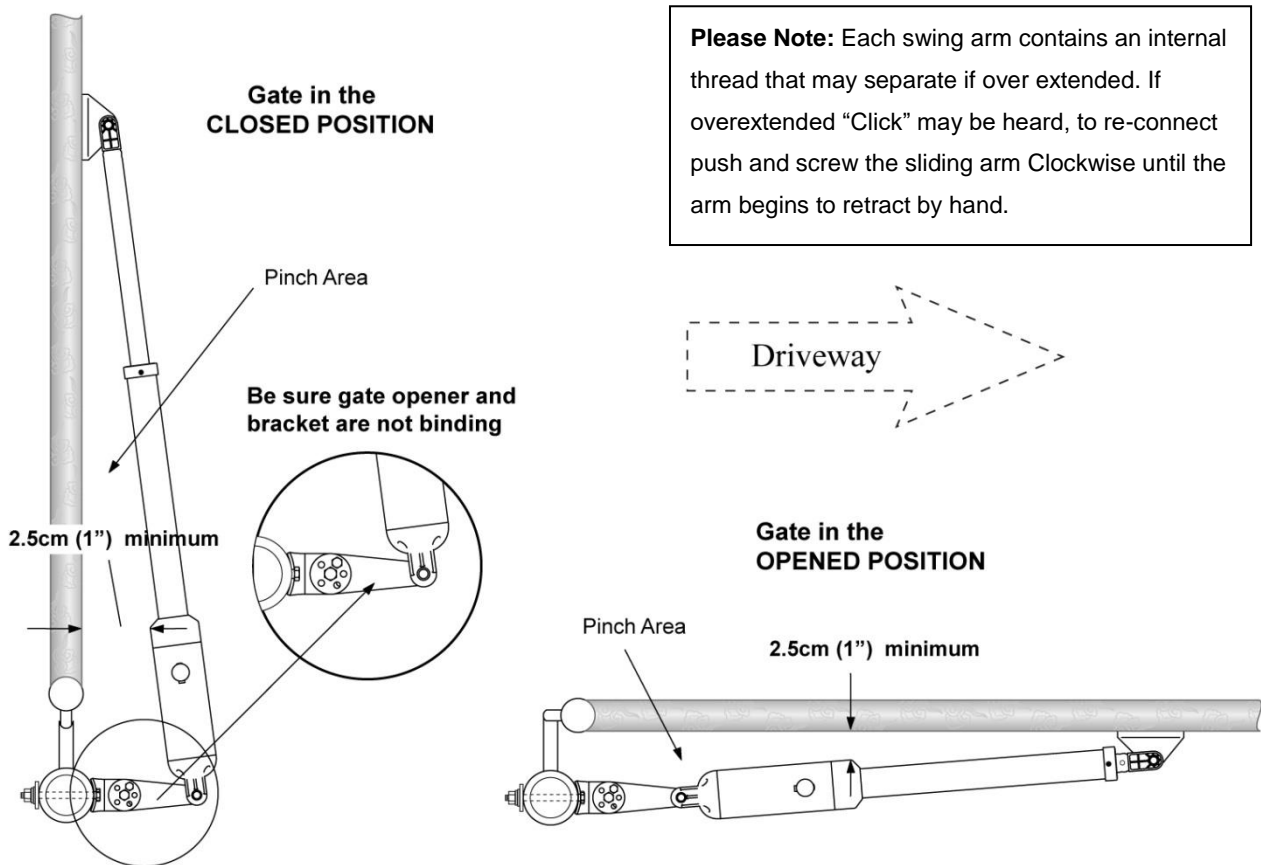

Figure 10

6. Manually close the gate and verify that it can reach or travel past the required closed position. If it does not reach the closed position, you will need to rotate the post pivot bracket, or adjust the position of the post pivot bracket assembly on the post. If the gate is past the fully closed position at full extension, this can be adjusted with the limit switches, refer to Page 22 or 23.
7. Mark the bolt-hole points on the gate post and the gate. We recommend marking the middle of each bolt slot on the Post Brackets and the Gate Bracket, this will allow slight adjustments in positioning. Once the holes are marked, remove the post bracket and gate bracket by taking off the C-clamps.

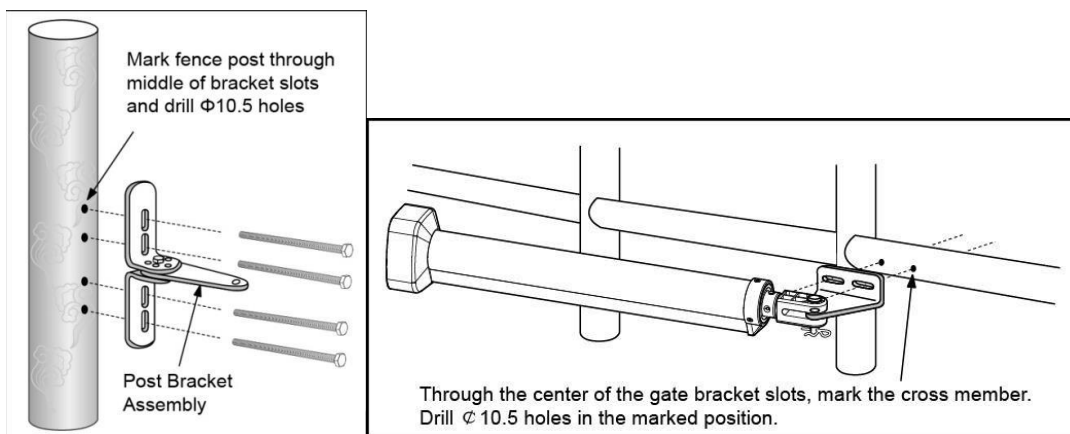

Figure 11

8. Drill 10.5 mm diameter holes through the post and the gate at the marked locations.

9. Attach the post bracket assemblies to the gate posts by inserting M10 x 200 bolts through each post bracket assembly and the drilled holes in the gate post. Fasten each bolt with one ϕ 10 washer, one ϕ 10 lock washer, and one ϕ 10 nut.
10. Attach the gate brackets to each gate by inserting two M10 x 75 bolts through the gate brackets and the drilled holes in the gates. Fasten each bolt with one ϕ 10 lock washer, and one ϕ 10 nut.
11. Cut off any part of the bolts that extend beyond the tightened nuts.
12. With the gate opener fully retracted and with the gate in the fully open position, reattach the gate opener to the Post Bracket Assembly and the Gate Bracket by inserting a clevis pin through the gate opener and the Post Pivot Bracket and another clevis pin through the gate opener and the Gate Bracket. Secure each clevis pin with a hairpin clip.

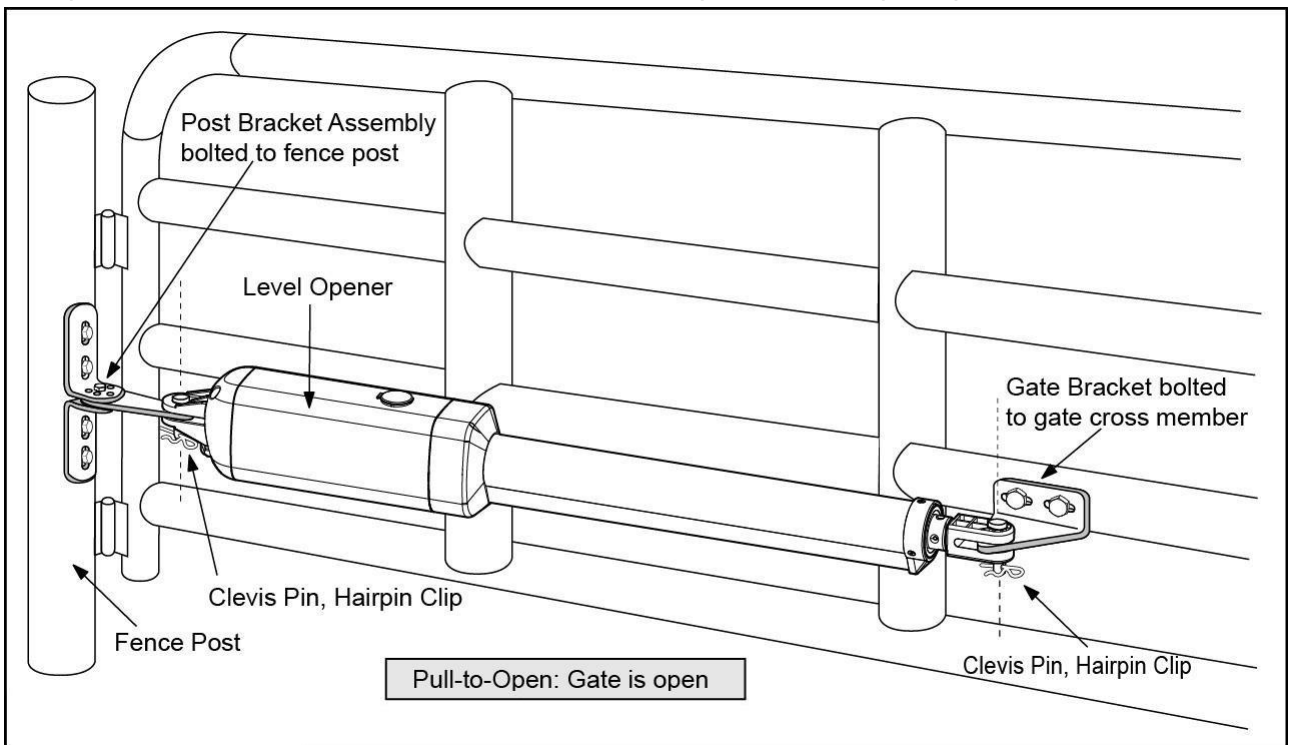

Figure 12

13. Check again that the gate swings smoothly by hand, and that the gate arm is level.
14. Open the release plug on the top of the gate arm, insert the release key, and turn the key 90° anti-clockwise. This puts the opener back into automatic mode.

Programming and Wiring

Control Board Wiring Diagram

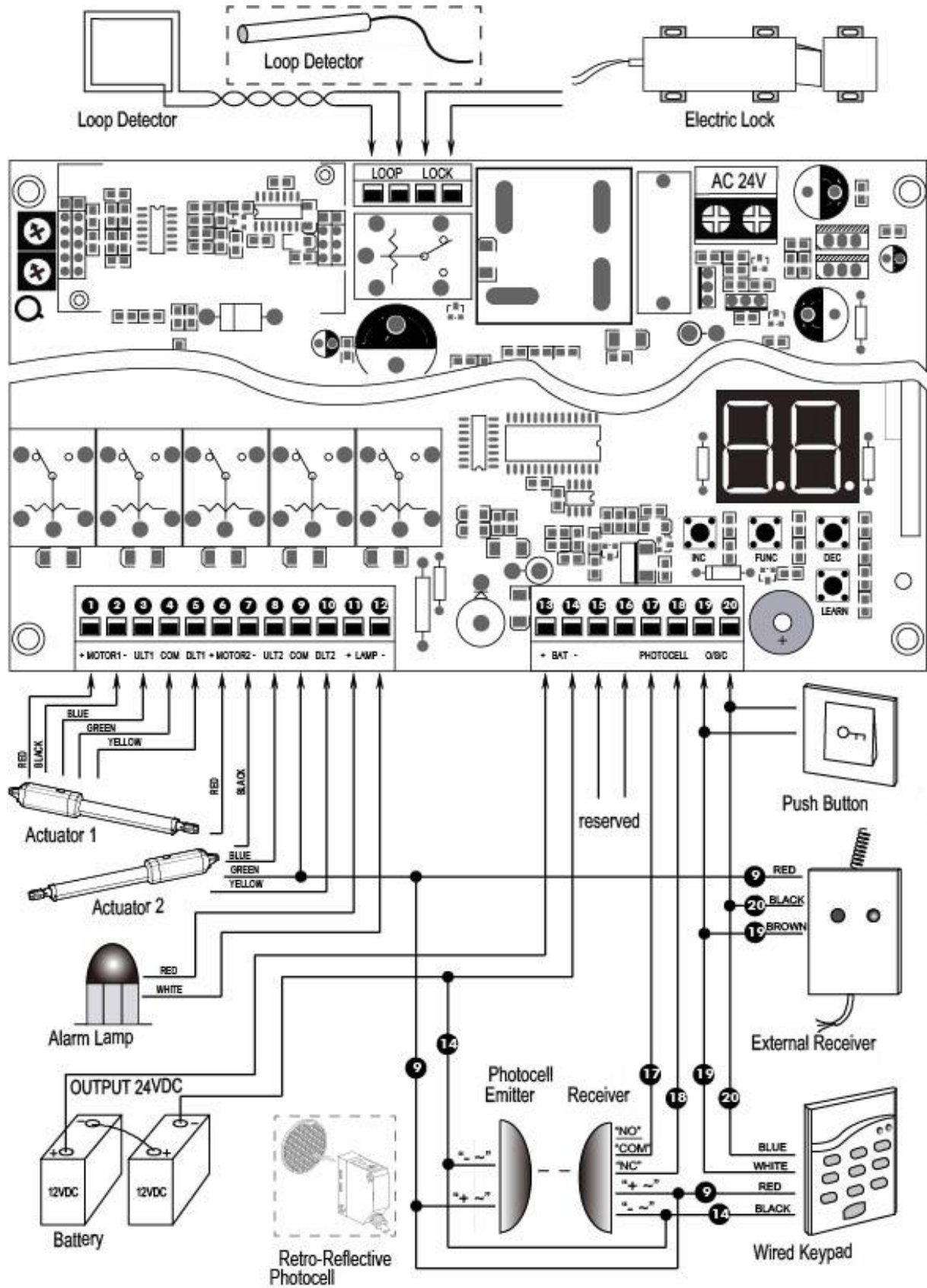

Figure 13

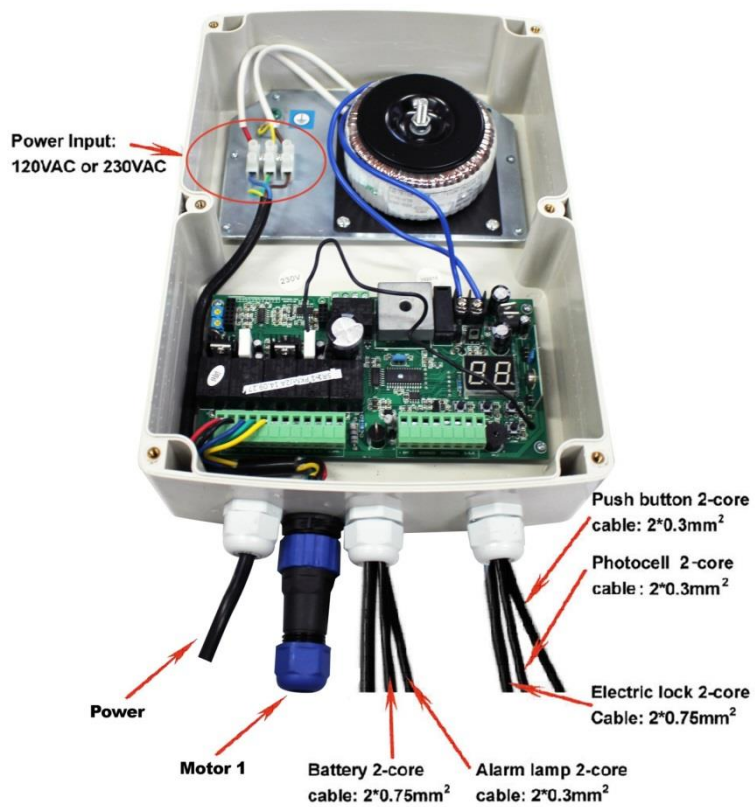
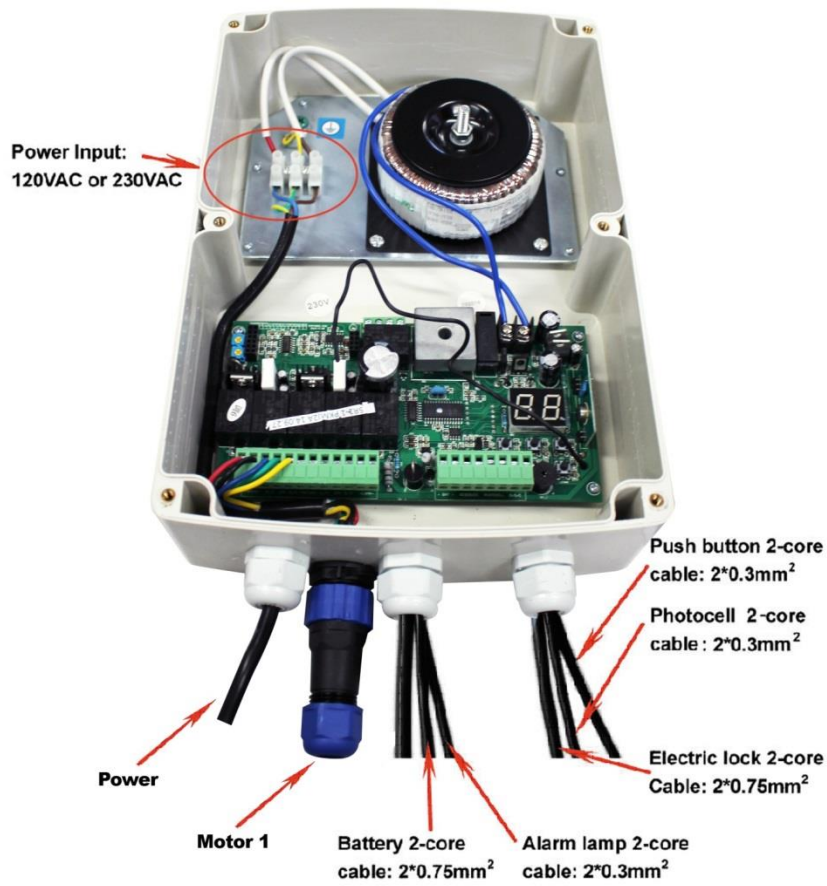

Figure 14

Mounting the Control Box

The control box comes with an Australian Standard power cord wired in. Do not extend the power cord more than 3m. All wiring at high voltage (240VAC/50Hz) must be done by a qualified electrician.

Remove the cover of the control box, and use 4 screws or bolts (not provided) to mount to a secure surface. Ensure that the control box is in a well ventilated area protected against rain and sunshine. The plugs must be facing downwards, and at least 100cm above the ground.

Connecting the Gate Arm

If installing GTR058 (Dual Swing Arm Kit), ensure that the control box is installed on the side of Gate Arm 1. Connect the Motor Plug on the Gate Arm to the socket on the control box labelled Motor 1, and tighten the sealing nut. (For Dual Arm model GTR058 only) Connect the Motor Plug on the second Gate opener to the socket labelled Motor 2, and tighten the sealing nut. Note: It is recommended that Gate Opener 1 is installed in the Master Gate, and Gate Opener 2 is installed in the Slave Gate.

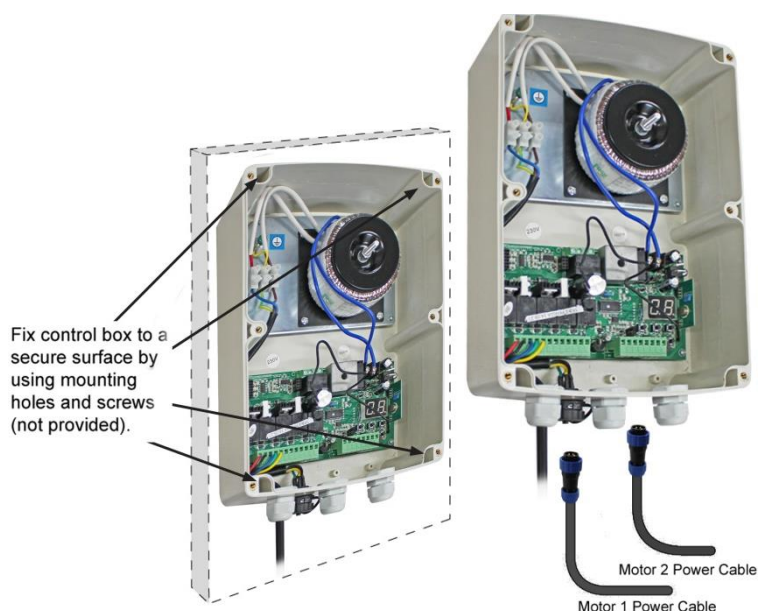

Figure 15



Figure 16

For any optional extras, insert the cables through the middle or right hand strain relief and into the control box by loosening the strain relief screw and feeding the cables into the control box. Check the length of the cables is long enough to reach their respective terminal block in the control box. Refer to Figure 13 for details on how to connect the extras.

Once all connections are made securely, retighten the sealing nut so that cables are well locked.

Programming

The following steps detail how to program the features of the gate opener. While the PCB is powered on, the digital display will flash the standby code '- -'. To enter programming mode, press and hold the 'FUNC' button for 4 seconds, and the digital display will flash 'P1'. Press the 'FUNC' button again to cycle through the settings. To change the setting, use the 'INC' and 'DEC' buttons to increase/decrease the value. Once programming has been completed, press the 'FUNC' button until the standby code '- -'.

P1: Single/Dual Gate Setting.

For GTR100 Single Gate Opener, recommended setting is '01'. For GTR058 Dual Gate Opener, set to '11'.

01 – Single Gate Arm Mode (Motor 1)

10 – Single Gate Arm Mode (Motor 2)

11 – Dual Gate Arm Mode

Default setting is '11'.

P2: Master/Slave Setting.

The Master Gate is the primary side that will open and close first. Refer to Figure 2 for illustration. Where possible, Motor 1 is recommended to be Master.

For GTR100 Single Gate Opener, leave this setting at '01'.

01 – Motor 1 is the Master, Motor 2 is the Slave

10 – Motor 2 is the Master, Motor 1 is the Slave

Default setting is '01'.

P3: Master/Slave Opening Interval.

Adjusting this value will change the time interval between the Master Gate opening and the Slave Gate opening. This value can be set between 0-9 seconds. Setting the value to '0' means both gates will open simultaneously, while setting the value to '9' means that the Slave Gate starts to open 9 seconds after the Master Gate.

For GTR100 Single Gate Opener, leave this setting at '3'.

Default setting is '3'.

P4: Master/Slave Closing Interval.

Adjusting this value will change the time interval between the Master Gate closing and the Slave Gate closing. This value can be set between 0-9 seconds. Setting the value to '0' means both gates will close simultaneously, while setting the value to '9' means that the Slave Gate starts to close 9 seconds after the Master Gate.

For GTR100 Single Gate Opener, leave this setting at '3'.

Default setting is '3'.

P5: Stall Force of Gate Arm 1.

The Stall Force is the amount of force required to stop the gate motor during operation. If an impact is detected during the opening cycle, the gate will stop. If an impact is detected during the

closing cycle the gate will stop, and then re-open.

For safety, this setting should be high enough that small objects such as branches or wind will not cause interruptions, but low enough to detect collisions with a person or vehicle.

The value can be set between 0-9. '1' means minimum force detected will stop the gate, '9' means maximum force.

Default setting is '3'.

***NOTE* The Stall Force is an important part of the safety features. After any adjustments are made, this function must be re-tested. Never increase the Stall Force to compensate for a binding or sticking gate.**

P6: Stall Force of Gate Arm 2.

As per above description, the value can be set between 0-9. '1' means minimum force detected will stop the gate, '9' means maximum force.

For GTR100 Single Gate Opener, leave this setting at '3'.

Default setting is '3'.

P7: Max Running Time of Gate Arm 1.

The Max Running Time can be set to stop the motor running after a set period of time, even if the limit switch has not been detected or the Gate Arm is in Manual Mode.

The value can be set between 1 – 50 seconds. '1' means the Gate Arm 1 will stop after 1 second.

Default setting is '40'.

P8: Max Running Time of Gate Arm 2.

The value can be set between 1 – 50 seconds. '1' means the Gate Arm 1 will stop after 1 second.

Default setting is '40'.

P9: Enable Infrared Photocell Setting.

Enable the setting when Infrared Photocell (GTR051) is being used.

00 – Infrared Photocell disabled.

11 – Infrared Photocell enabled.

Default setting is '00'.

PA: Auto Close Setting.

This setting allows you to enable and adjust the Auto Close feature. When enabled, the gate will automatically close after the specified amount of time.

The value can be set between 1 – 99 seconds. '00' means that the Auto Close feature is disabled and the gate will stay open until the remote button is pressed again. '1' means the gate will start to close 1 second after it has finished opening.

Default setting is '60'.

Pb: Soft Start Setting.

The Soft Start feature means that the gate will start to open slowly for a set period of time, then open at the regular speed. This can prevent wear and tear on the Gate Opener and the gate itself.

The value can be set between 1 – 9 seconds. '1' means that the Gate Arm will open slowly for 1 second then proceed at the regular speed.

Default setting is '3'.

PC: Soft Stop Setting.

As above, the Soft Stop feature means the gate will slow before reaching the limit position and stopping.

This feature must be set by adjusting the amount of time running at regular speed before slowing down. You will need to know the total gate opening/closing time.

The value can be set between 1 – 28 seconds. The calculation can be done as follows:

Soft Stop Period = Total Gate Opening/Closing Time – Soft Start Period – Regular Running Period.

So for example, if the Soft Start is set to '3', the gate takes 23 seconds to open/close, and you want a Soft Stop of 3 seconds, the calculation would be $23 - 3 - 3 = 17$ seconds, so you should set this value to '17'.

Default setting is '15'.

Pd: Reset to Default Settings

While on the Pd setting, press and hold the 'INC' or 'DEC' button, and the digital display will show 'dF'. All settings will be restored to the default settings.

The digital display will show the status of both Gate Arms during operation. The first symbol refers to Motor 1, and the second symbol refers to Motor 2. During opening, the symbol will display 'n', and during closing the symbol will display 'u'.

Pairing Remote Controls

While the power is on, and the control box cover is removed, press the button 'LEARN' on the control board, until the LED turns on, then release the button. While the light is on, press the first button on the remote control twice, the LED will flash repeatedly and then turn off when remote control is paired. Up to 10 remote controls can be paired. Refer to Figure 18.

Clearing Remote Controls

To delete all paired remote controls, press and hold the button 'LEARN' for approx. 8 seconds. When the 'LEARN' LED turns off, all previously paired remote controls that will be deleted.

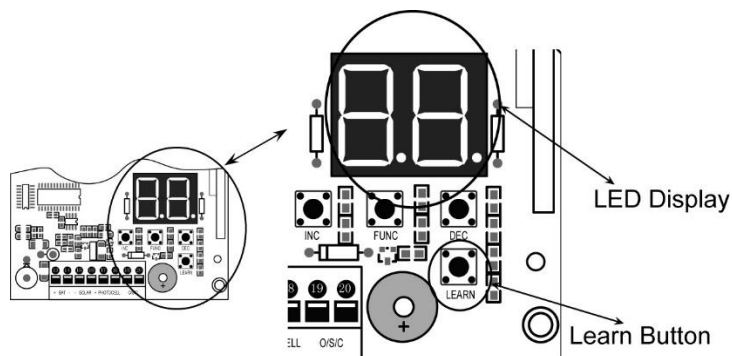

Figure 17

Adjusting the Limit Switch

The gate opener uses magnetic limit switches to determine open and close positions. Limit Switches B (and D) may need to be adjusted to ensure the gate motor closes at the correct position. To adjust the limit switch, use a screwdriver to loosen the screw of Limit Switch B (or D),

slide to the correct position, and then tighten the screw again.

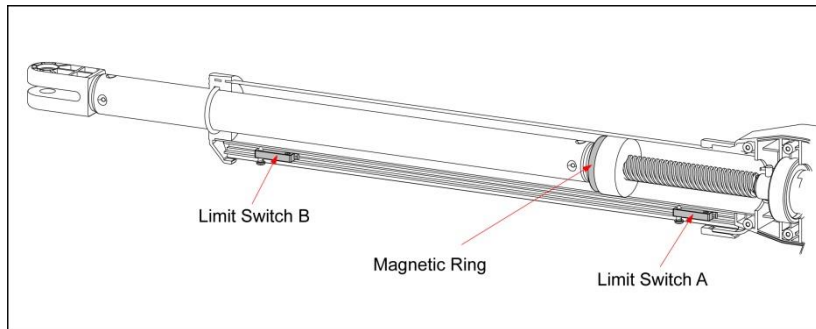

Figure 18

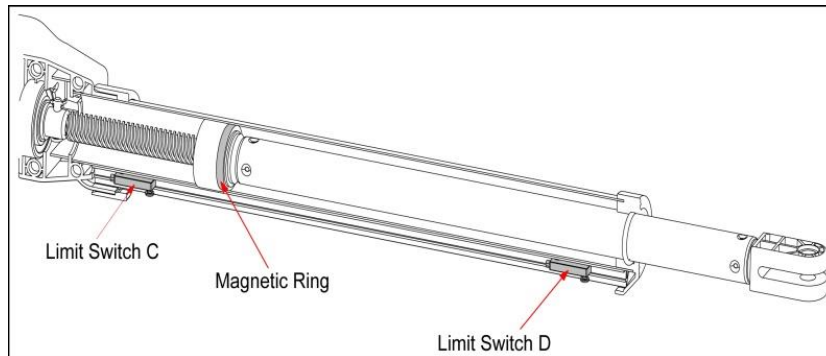

Figure 19

Note: Limit Switches A and C should not be adjusted from the factory setting.

Infrared Photocell (GTR051)

Photocells offer an additional safety feature. While closing, if the ray of the Infrared Photocell is blocked, the gate will stop and reverse immediately, to protect user and property security. To install photocells, connect wiring as per Figure 13. The setting P9 should be set to '11' to enable the Infrared Photocell. The distance between photocell receiver and photocell emitter should be not less than 2 meters, or it may affect the operation of the photocell.

Note: To connect the screw type terminals on the circuit board, you will need to firmly pull the green terminal off the circuit board, and use a small screwdriver to loosen the screw. The wires should be clean with no frayed wires. Insert the wire into the required terminal, ensuring full contact with the metal. Retighten the screws, and then tug on the wire to ensure that it is securely fastened. Once all wires are inserted and fastened, push the green terminal back into the circuit board, making sure it clicks in and is sitting flush. Lastly, check that the wires are not contacting a neighbouring terminal, as this can cause a short circuit.

Battery Backup (Optional Extra)

The Gate Opener can be connected to 2 x 12V batteries in series to provide a battery backup. This will allow the Gate Opener to operate in the event of a power outage. The batteries will be kept charged by mains power, or alternatively can be charged by Solar Power (see GTR097 below).

Solar Panel Kit (GTR097)

The GTR058 and GTR100 can be used with a solar panel to charge the batteries. Our GTR097 Solar Kit contains a solar panel, solar regulator and all connecting cables for easy installation. To connect the solar panel and the solar charge controller refer to the manual of the GTR097 as well

Figure 20.

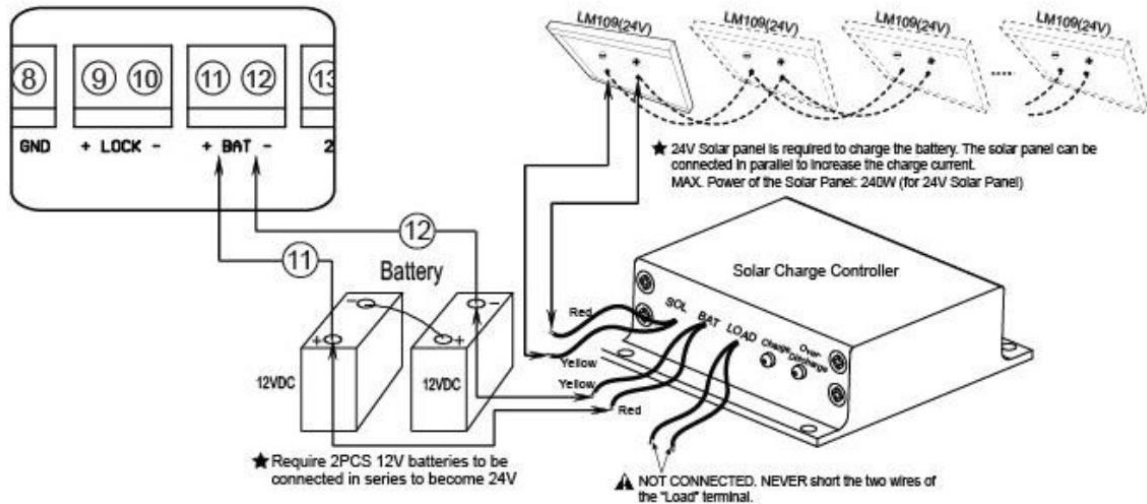

Figure 20

Note: Using some optional extras with solar panels may cause the battery to drain quickly, and may require larger solar panels and batteries.

Push To Open

The GTR058 and GTR100 can be used as a Push-To-Open gate, you may need to use an Optional Push-To-Open Bracket (contact Richmond Wheel & Castor), or mount the Post Bracket Assembly to the side of the post. Note that in this configuration, the gate arm is retracted in the Open position, and extended in the Closed position. Refer to Figures 21 and 22 for details on how to mount. To enable Push-To-Open, you will need to remove the red and black wires from MOTOR+ and MOTOR- and replace in the opposite configuration. Refer to Figure 23 for details.

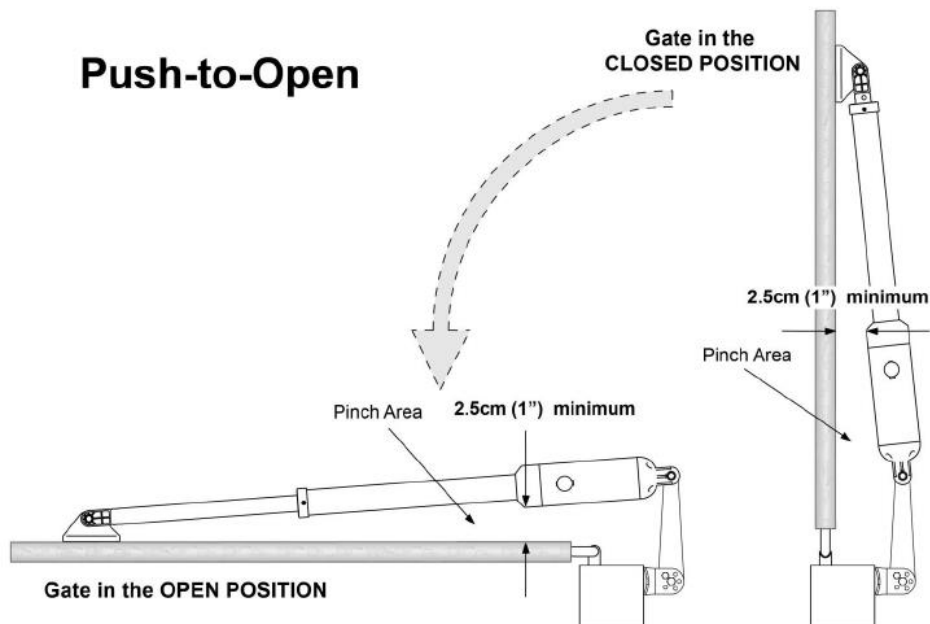

Figure 21

Please Note: Each swing arm contains an internal thread that may separate if over extended. If overextended "Click" may be heard, to re-connect push and screw the sliding arm Clockwise until the arm begins to retract by hand.

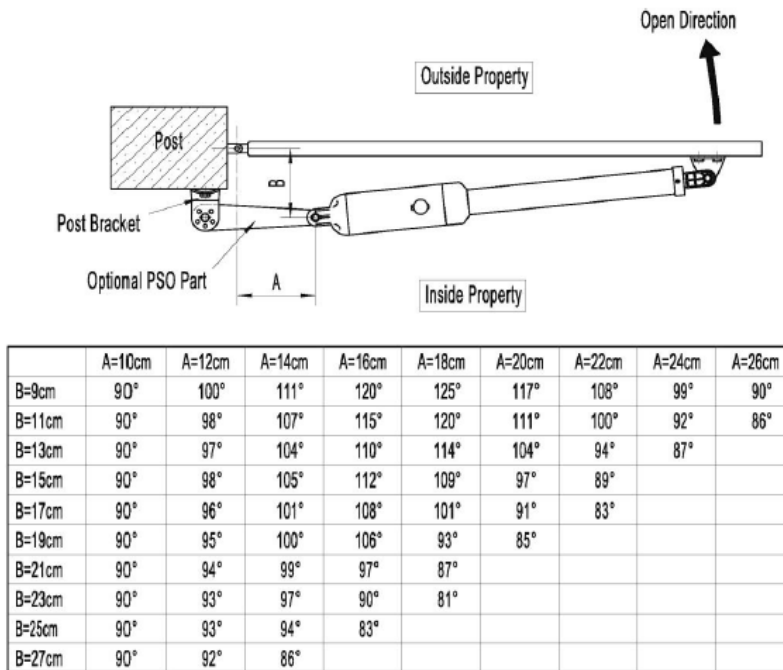

Figure 22

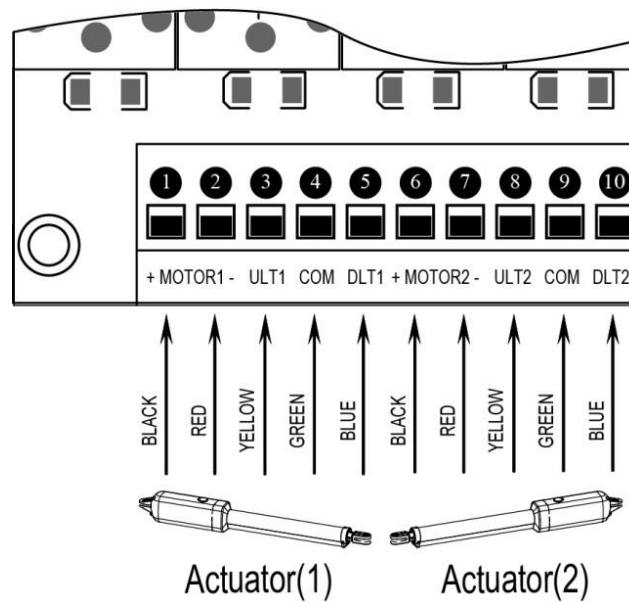

Figure 23

Other

Maintenance

Under normal operation, the gate should be checked every 6 months:

- Lubricate gate hinges
- Check and tighten all fixture bolts
- Check for loose and corroded wires.
- Always check the stall force after performing any maintenance. If this function does not work, do not use the gate motor until this is rectified.
- Use the key to put the gate arms in manual mode and check opening/closing sequence by hand.
- Discretion should be used to check more often, and after heavy wind and storms.

Troubleshooting

| Problem | Possible Reason | Solution |
|--|--|---|
| Digital display does not turn on. | <ol style="list-style-type: none"> 1. Power has been disconnected 2. PCB fuse has blown. 3. PCB is damaged. | <ol style="list-style-type: none"> 1. Check power cord is plugged in, and inspect cord for any damage. 2. Check fuse on PCB, replace if required. 3. Contact Richmond Wheel & Castor Co for replacement PCB |
| The gate stops during opening/closing. | <ol style="list-style-type: none"> 1. Stall Force is set too low. 2. Gate hinges are damaged. | <ol style="list-style-type: none"> 1. Increase the Stall Force (Settings P5 and P6) to the minimum value that the gate opens. 2. Regrease hinges and check for any misalignment. Put the motor arm into manual mode and check the gate opens freely by hand. |
| The gate stops immediately after it starts moving. | <ol style="list-style-type: none"> 1. Obstruction is detected. 2. Stall Force is set too low. 3. Max Running Time is set too low. | <ol style="list-style-type: none"> 1. Check for obstructions and remove. 2. Test with increased Stall Force by adjusting settings P5 and P6. Set the Stall Force to the minimum value that the gate functions correctly. 3. Increase the Max Running Time by adjusting settings P7 and P8. |
| Remote Control doesn't work. | <ol style="list-style-type: none"> 1. Remote Control battery is flat. 2. Remote Control is not paired correctly. | <ol style="list-style-type: none"> 1. Check LED lights up when button is pressed. If not, change the remote control battery (A27 battery required). 2. Repeat pairing procedure. |
| Gate can open but does not close | <ol style="list-style-type: none"> 1. Photocells are obstructed. 2. Photocell not mounted correctly. | <ol style="list-style-type: none"> 1. Check and remove any obstructions. 2. Make sure photocell beams are correctly positioned and at least 2 meters apart. |
| Gate does not automatically close | <ol style="list-style-type: none"> 1. Auto Close settings are incorrect. 2. Gate is incorrectly set to Push-to-Open or Pull-to-Open | <ol style="list-style-type: none"> 1. Check that setting P9 is set correctly. 2. Check that the motor cables are wired correctly for Push-to-Open or Pull-to-Open. |
| Gate arm wont retract | <ol style="list-style-type: none"> 1. The arm is overextended. Each swing arm contains an internal thread that may separate if over extended. | <p>If overextended "Click" may be heard, to re-connect push and screw the sliding arm Clockwise until the arm begins to retract by hand</p> |

Technical Support

For support or assistance with installing your gate motor, ring your local Richmond Wheel & Castor Branch on 1300 474 246. For detailed technical support, ring our Engineering Department on 03 9551 2233.

According to the Waste of Electrical and Electronic Equipment (WEEE) directive, WEEE should be separately collected and treated. If at any time in future you need to dispose of this product please do NOT dispose of this product with household waste. Please send this product to WEEE collecting points where available.

