

PNEUMATIC/PUNCTURE PROOF CASTORS

UP TO 180KG / CASTOR

Ideal for outdoor use, whether used over soft or hard ground, a pneumatic castor features a cushioned comfortable ride characteristic to protect the load.

Richmond Pneumatic Castors are fitted with the highest quality rubber tyres and sealed bearings, increasing water resistance and decreasing rolling resistance.











Pneumatic castors are ideal for use on agricultural equipment and for making sports equipment such as batting cages, nets and equipment trolleys more mobile on soft ground.













MOUNTING PLATES AVAILABLE IF REQUIRED
page 95

S8861

PNEUMATIC SERIES

 Diameter (mm)	 Width (mm)	 Wheel Type	 Wheel Code	 Bearing Type	 Load Capacity	 Height (mm)	 Swivel Radius	 Rigid Code	 Swivel Code
220	60	Pneumatic	PN8860	Ball	100	260	160	R8862	S8861
255	85	Pneumatic	PN1066	Ball	180	315	200	R1068	S1067

PUNCTURE PROOF SERIES

 Diameter (mm)	 Width (mm)	 Wheel Type	 Wheel Code	 Bearing Type	 Load Capacity	 Height (mm)	 Swivel Radius	 Rigid Code	 Swivel Code
215	55	Puncture Proof	PF8881	Ball	70	245	160	R8835	S8834
255	83	Puncture Proof	PF1084	Ball	100	305	200	R1089	S1088

- WHEELS ALL HAVE SEALED PRECISION BALL BEARINGS FOR LONG LIFE.

BASEPLATE DIMENSIONS & DRILLING PATTERNS FOR PNEUMATIC CASTORS

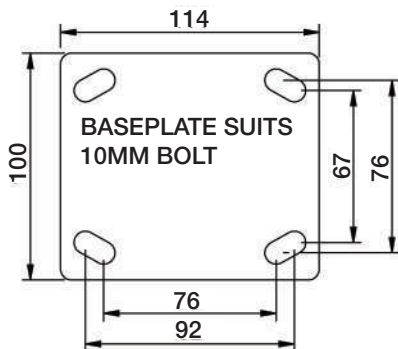

R8862



S1067B

*SHOWN WITH OPTIONAL BAND BRAKE